

# ZOOMLION

Makine 2B grafiği

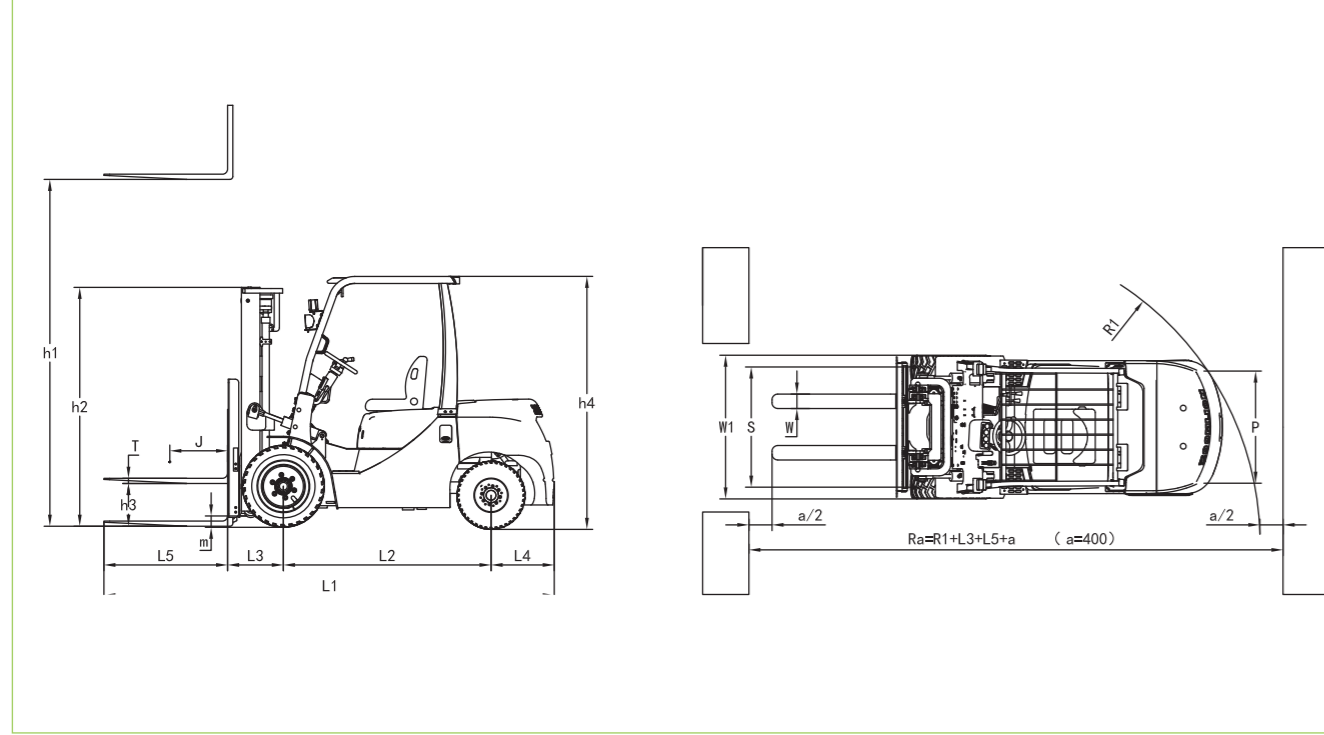

KAPASİTE TABLOSU

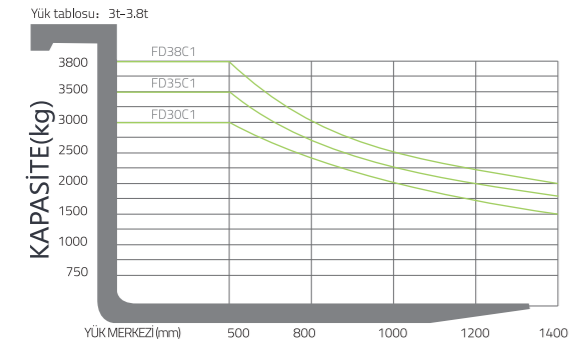

Opsiyonel Motorun Özellikleri

Model	Nominal Güç/Hz (kW/c.p.m)	Nominal tork (Nm/c.p.m)	Yer değiştirme (L)	Model (T)
-	-	-	-	-
Isuzu 4JG2	46/2450	184.7/1700	3.059	3-3.8
Isuzu C240	34.3/2500	137.7/1800	2.369	3
Xinchai C490	40/2650	160/1800-2000	2.67	3-3.5

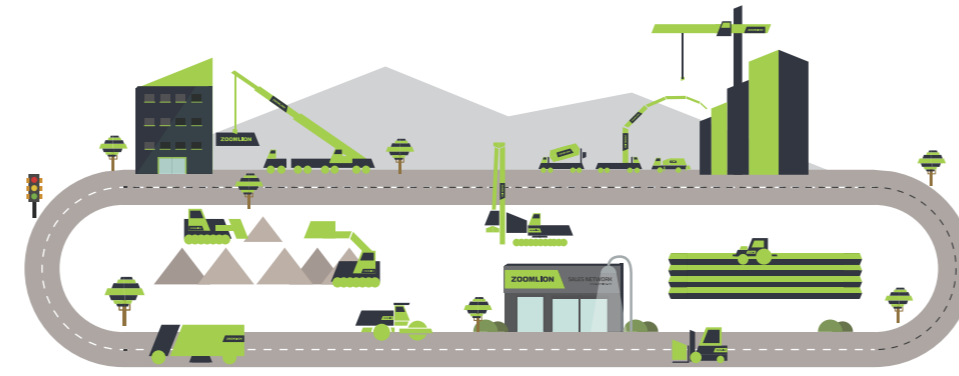

## FD30/35 DİZEL FORKLİFT

### ZOOMLION ÇİFA MAKİNE SAN. VE TİC. A.Ş.

ADRES: Aydıntepe Mah. D-100 Karayolu Cad. No: 16 Tuzla/İstanbul - Türkiye  
TEL: (+90) 444 1 157 • MAIL: satis@zoomlion.com • WEB: www.zoomlion.com.tr



Ayrıntılar için tıklayın

ZOOMLION

